

4 axis profile CNC Machining center

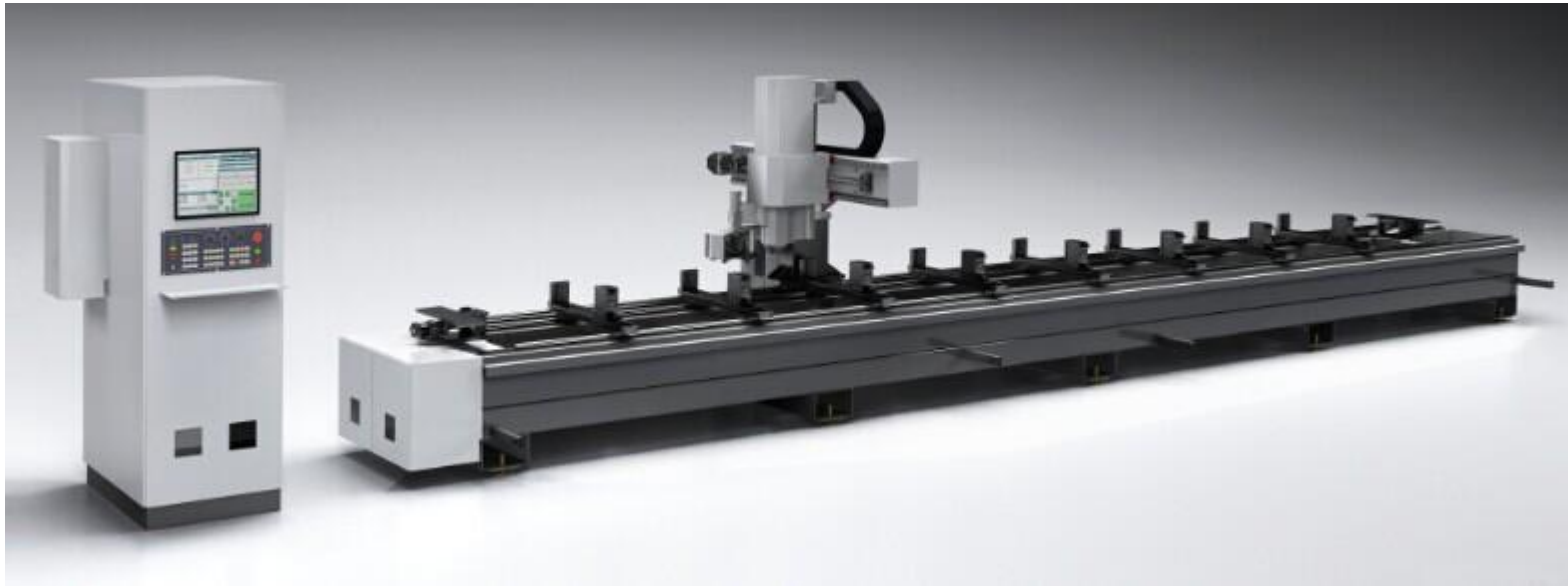

Feature:

1. Using advanced industrial CNC systems, friendly human-machine interface, device operation is simple/
2. Suitable for aluminum alloy, aluminum and wood composite [profile](#) profiles and other light alloys of copper, as well as the u-PVC profile processing.
3. Within a range of $90^{\circ} \sim 0^{\circ} \sim 90^{\circ}$ 4-axis machining.
4. In one clamping profiles complete milling, drilling, chamfering, grooving and other multi-functional precision machining.
5. Made of high strength welding structure, after heat aging after annealing processing guarantee high rigidity and high stability.
6. Adopts imported high precision linear guideways, ball screws, gear racks and servo motor, ensuring smooth motion, positioning and processing of high precision.

7.High-quality imported automatic tool change for high speed motorized spindle ensure stability, stability of rotation noise, cutting ability.

8.Magazine is equipped with 12-station capacity, adjustable pneumatic special fixture ensure efficient processing.

9.Double table for two, or two kinds of profile machining, interactive feeding, non interference.

10.Multiple safety protection structure to ensure operator safety

11.The device adopts ER25 collect, clamped milling tool shank diameter is 2~16,Optional ER32 collect clamped milling tool shank diameter is 2~20;ER40 collect clamped milling tool shank diameter is 3~27

Application Industry

Transportation products manufacturing (trains, cars, ships, etc) , Medical equipment, bathroom accessories, windows&doors, curtain walls, interior decoration and other industries.

Technical Parameters:

X-axis stroke	7000mm
X-axis feed rate	0~60m/min
X-axis positioning accuracy	±0.05mm
Z-axis stroke	300mm
Z-axis feed rate	0~20m/min
Z-axis positioning accuracy	±0.02mm
Power Specification	380V/50Hz
Total Power of Machine	12.5kW
Machine Size	11300x2350x2550mm
Y-axis stroke	650mm(3 axis) 435mm(4axis)

Y-axis feed rate	0~48m/min
Y-axis positioning accuracy	±0.02mm
Repeat location accuracy	±0.02mm
Roughness	Ra 6.3 um
Spindle Power	7.5kW
Spindle Speed	0~24000rpm
Working Pressure	0.6~0.8MPa
Weight	4800kg

Working video:

<https://www.youtube.com/watch?v=a7tu0Axgvco>